



Precision Drainage Monitoring with Our Drainage Sensor Kit

Efficiently Measure and Manage Fluids for Optimal Soil Root-Zone Conditions



The Drainage Sensor Kit utilizes a specialized funnel, orifice 50 cm², to measure fluids effectively. Directed into a self-emptying bucket, the liquid is managed by a robust magnet, precisely calibrated to facilitate quick tipping (in less than 300 milliseconds) and seamless return to its regular position. This innovative design allows the collection of excess water from the substrate or soil.

The bucket, with a capacity of approximately 5ml, completes one pulse with each fill and empty cycle. The number of pulses, each equivalent to 5ml, is precisely measured by the drainage sensor. Experience unparalleled accuracy in fluid measurement with our Drainage Sensor Kit, ensuring optimal soil health management.

1. Funnel with grille
2. Self-emptying tipping bucket
3. PCB with reed switches
4. Magnet
5. Base
6. Adjustment screw
7. Housing

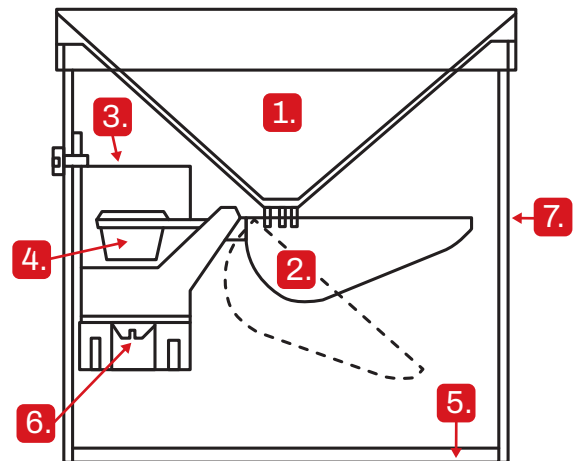

What do you get in a package?

1. Pulse counter
2. Drainage sensor
3. 1x AA battery

It is important to note that the sensor is already connected to the pulse counter, so all you need to do is to pair the Drainage sensor to the base station. Let's begin by connecting the Drainage sensor to the base station.



Pairing sensors to the Aranet PRO / PRO Plus base station

Sensors can be paired one-by-one or in batches. When pairing the sensor, it should be located within 20 meters of the Aranet PRO/PRO Plus base station. The pairing procedure is as follows:

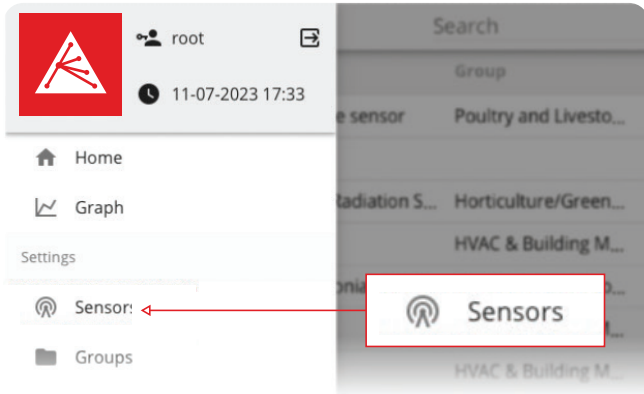

1. In the user interface of the base station accessed through **WiFi-IP** in a web browser, go to **Sensors**.

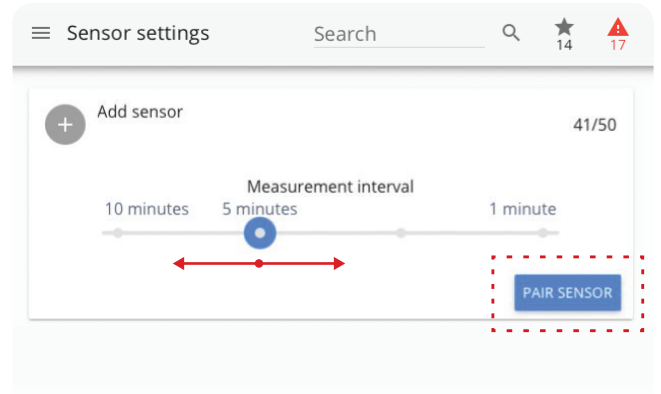

2. Choose the measurement interval, then click **PAIR SENSOR**

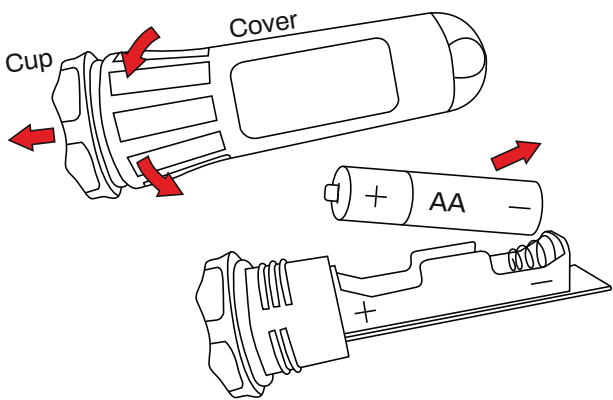

3. Open the sensor cover and remove the battery if it has been already inserted. Don't twist the cup, to avoid cable damage.

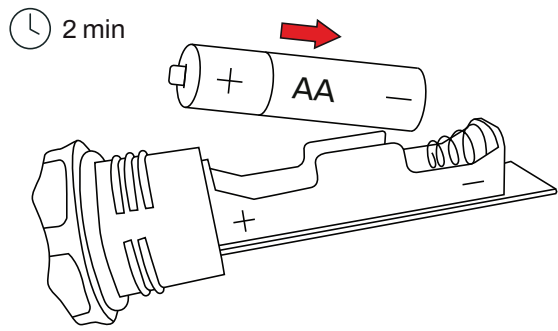

4. The 2 min timer indicates the window to insert the battery in the sensor. Correct battery type for each sensor is indicated in its datasheet.

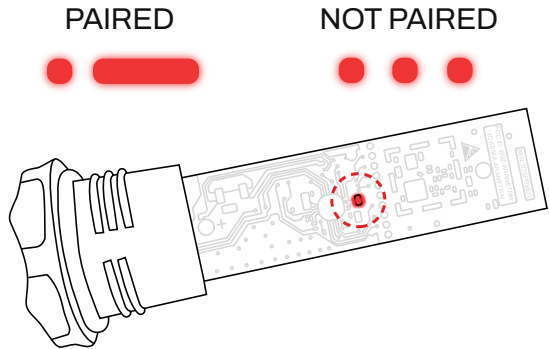

5. Successful pairing is confirmed by one short and one long LED light flash and takes up to 30 seconds. Failed pairing is indicated by three short flashes.

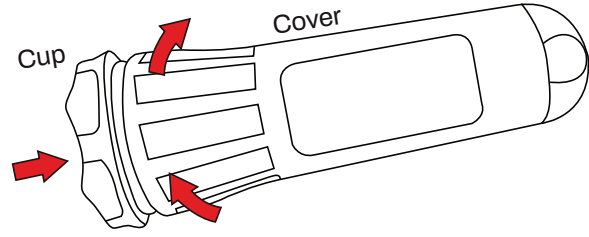

6. After successful pairing, close the sensor by screwing the sensor cover back on the cup.

Continue pairing other sensors. To pair all sensors in your batch, repeat step 3 with all sensors from your batch. When finished pairing all sensors, continue to step 7.

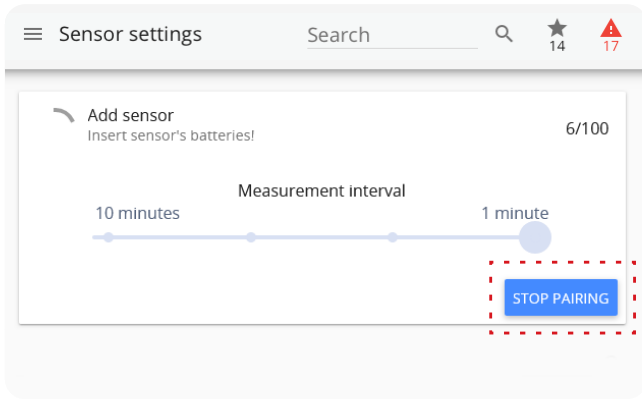

7. Finish pairing. When you finish pairing all sensors, press “STOP PAIRING” button in the Base station web-interface or wait for the timer to stop the pairing process automatically.

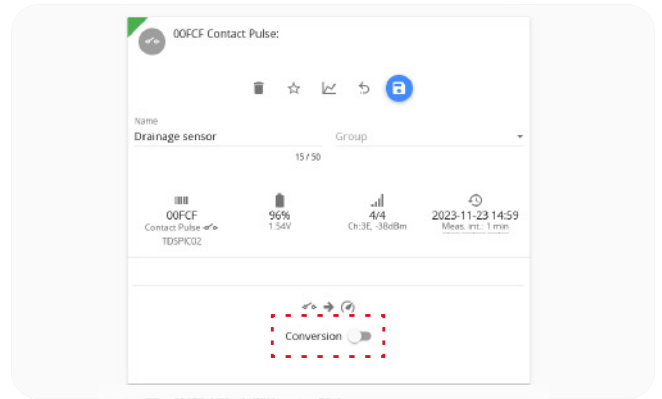

8. Within the 'Sensors' section of the base station's WEB interface, you have the option to enable the conversion of the counted pulse values into other units.



9. To do that switch the Conversion on, and use the drop-down menu to choose a predefined Dimension and unit.

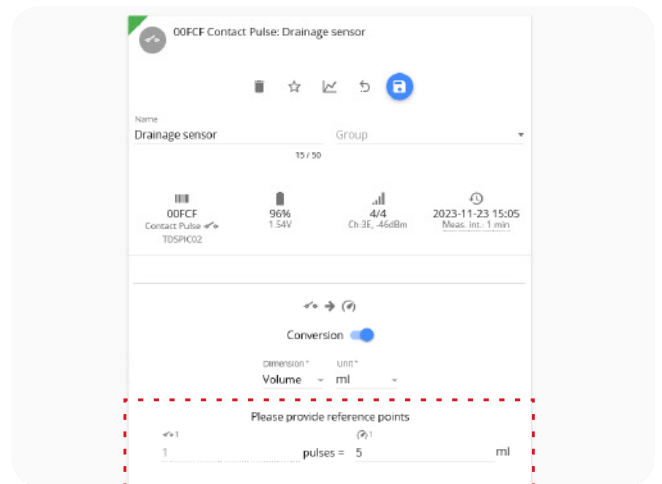

10. The pulse counter counts the number of cycles (fill and empty together) resulting in water volume monitoring. Both the count-per-measurement interval and the cumulative count are registered. Within the WEB interface you can convert and represent these measurements in the preferred volume units: volume in liters, milliliters or gallons.

- 1 pulse = 5 ml
- 1 pulse = 0.005 l
- 1 pulse = 0.0013 US gallons

How to Use the Drainage Sensor?

1. Installation:

Apply the Drainage sensor within your greenhouse's drainage system. Given variations in water management systems from one greenhouse to another, ensure the implementation is tailored to suit your specific system and needs.

2. Pulse Counter Placement:

Position the pulse counter radio transmitter as high as possible for optimal radio coverage. This step can become crucial as water interference can impact radio coverage. The higher placement helps mitigate potential disruptions.

Good Practice Recommendations:

Establish sample plots, known as reference plants, where all aspects are systematically monitored. Distribute these reference plants evenly throughout the greenhouse for comprehensive monitoring and control. This practice ensures effective utilization of the Drainage sensor for enhanced water management.

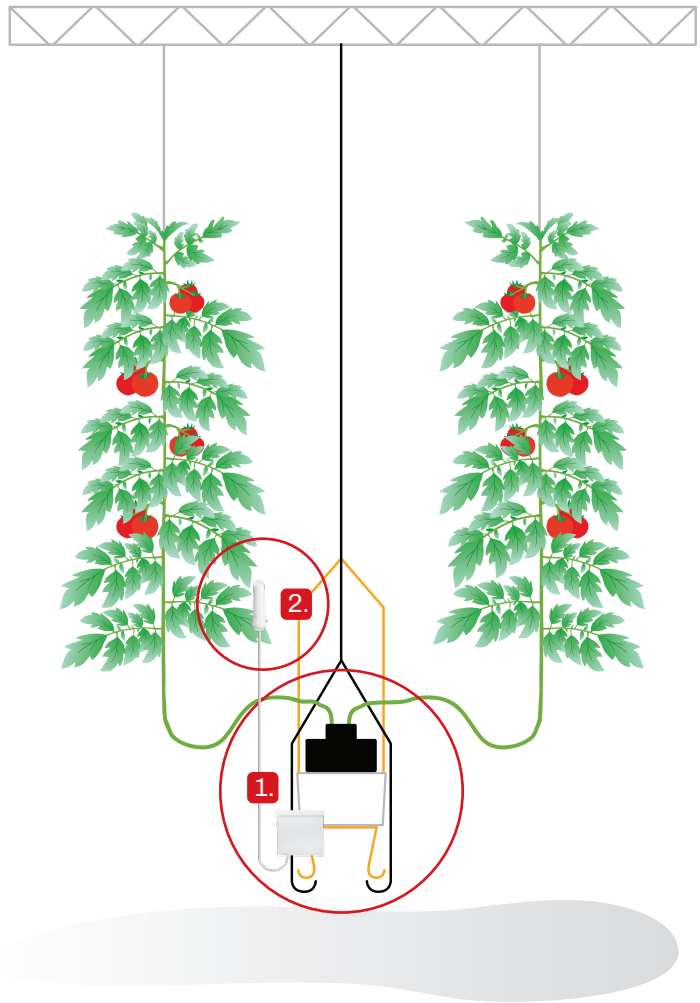

If you experience any issues, please reach out to our tech support for prompt assistance at support@aranet.com.